

FLOODLIGHT
APPLICATION
GUIDE



KIMLIGHTING

HUBBELL®
Lighting

STATIC WHITE
& RGBW COLORS

GUIDE

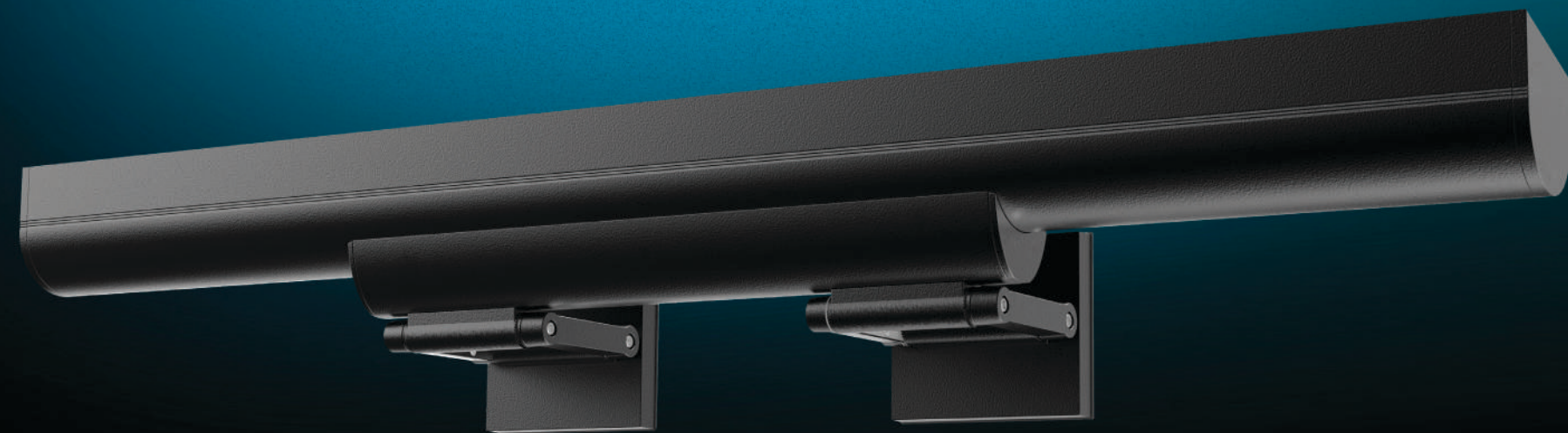

intent linear floodlights

The Intent linear floodlight family joins Kim Lighting's extensive floodlight offering. This compact architectural floodlight provides optimal appearance and performance for exterior wall washing, grazing or sign lighting applications in Static White, RGBW and RGBA configurations.

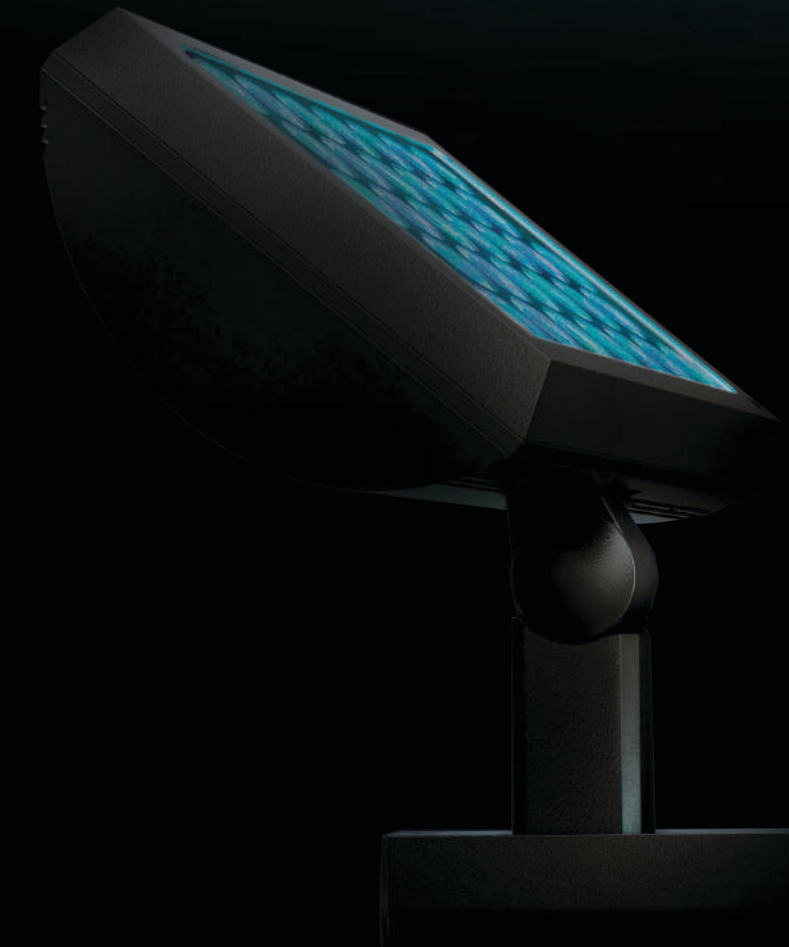

The striking, timeless form of Kim Lighting's KFL Collection floodlights seamlessly blends high performance optics, controls, scalability and architectural mounting options that cover a variety of applications and enhance their environment.

KFL Collection

WHITE & COLOR APPLICATIONS

GRAZING

- WASHING
- COLUMN LIGHTING
- SIGNS
- CANOPY LIGHTING
- SPOT LIGHTING
- LANDSCAPE AND TREES
- AREA LIGHTING
- BRIDGES

desired effect

Wall Grazing is a technique where lighting is positioned close to the wall with the intent of highlighting the textures of the wall. Wall grazing is a popular technique used in landscape and façade lighting. This technique is commonly used on natural materials such as stone to bring out variety and imperfections in the texture.

common distribution

Wall Grazing



INTENT - COLOR & WHITE

GRAZING

general guideline

By placing the lights close to the wall it forces the beam of light to hit the wall at a narrow angle. This narrow angle highlights the textures of the wall by creating shadows. The size of the shadowing can be adjusted by moving the beam of light closer or further from the wall.



WHITE & COLOR

APPLICATIONS

GRAZING

WASHING

COLUMN LIGHTING

SIGNS

CANOPY LIGHTING

SPOT LIGHTING

LANDSCAPE AND TREES

AREA LIGHTING

BRIDGES

desired effect

Wall Washing is a description used when the intent is to light a wall evenly. This is most commonly used when lighting murals, signage, or drawing attention to a vertical surface. Washing walls will help remove the visual appearance of any surface inconsistencies.

common distribution

Wall Washing



INTENT - COLOR & WHITE
KFL - COLOR

WASHING

general guideline

Luminaire setback is an important metric for wall washing. Space between the lit surface and the luminaire will help create even illumination on the wall and remove the possibilities of shadowing. Fixture spacing must also be considered to avoid scalloping on the wall.

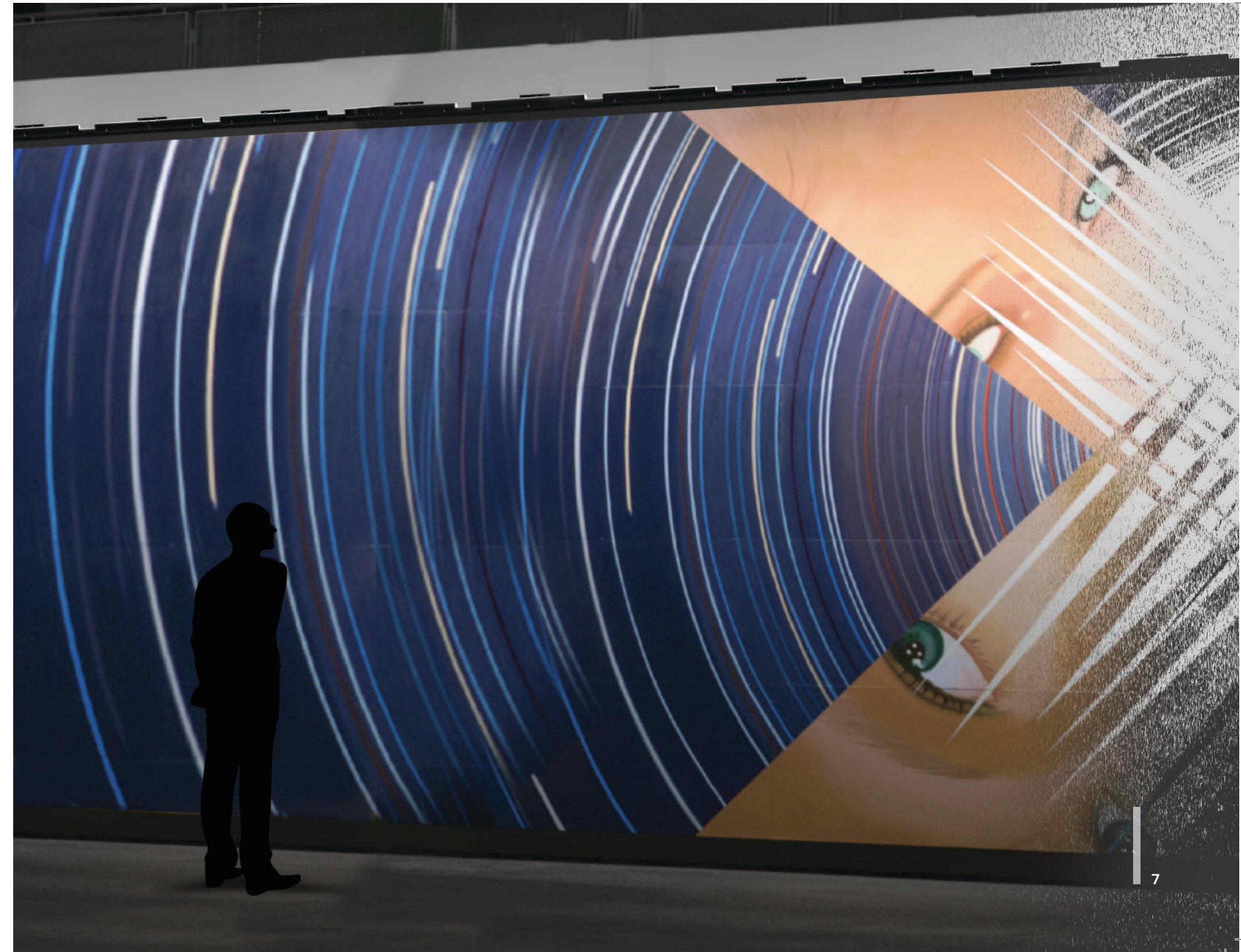

WHITE & COLOR

APPLICATIONS

GRAZING

WASHING

COLUMN LIGHTING

SIGNS

CANOPY LIGHTING

SPOT LIGHTING

LANDSCAPE AND TREES

AREA LIGHTING

BRIDGES

desired effect

Column lighting is a lighting technique where a narrow beam of light is aimed upward to highlight the desired target. Column lighting is used to highlight architectural features of buildings or sculptures.

common distribution

Spot



INTENT - COLOR
KFL - COLOR

Narrow



INTENT - COLOR & WHITE
KFL - COLOR & WHITE

COLUMN lighting

general guideline

The intensity and length of the beam can be adjusted by modifying the setback of the luminaire. Evaluate center beam candlepower to help determine the intensity in the center of the luminaire's beam. Consider using optical accessories such as a glare shield or barn doors to prevent light from spilling off of the desired surface reducing glare.



WHITE & COLOR

APPLICATIONS

GRAZING

WASHING

COLUMN LIGHTING

SIGN

CANOPY LIGHTING

SPOT LIGHTING

LANDSCAPE AND TREES

AREA LIGHTING

BRIDGES



desired effect

Illuminating signs is similar to wall washing but may have physical boundaries. Sign lighting can be achieved by using a number of lighting effects; the type of lighting used would be based on the type of sign and the desired effect.

common distribution

Horizontal Distributions



INTENT - WHITE
KFL - COLOR & WHITE

SIGN

general guideline

Luminaire setback is an important factor in sign lighting if the goal is to evenly illuminate the sign. Rectangular signage is more common than square, so vertical and horizontal distributions can be helpful in optimizing target illumination.



WHITE & COLOR

APPLICATIONS

GRAZING

WASHING

COLUMN LIGHTING

SIGN

CANOPY LIGHTING

SPOT LIGHTING

LANDSCAPE AND TREES

AREA LIGHTING

BRIDGES

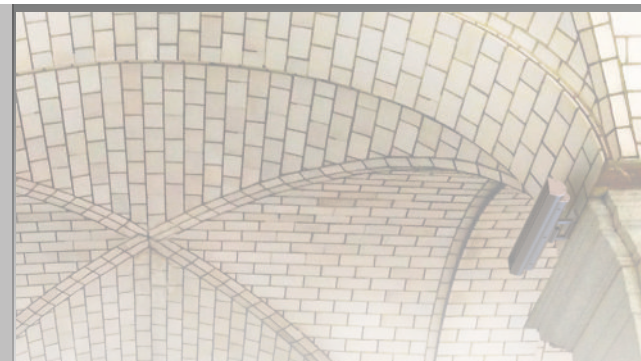

desired effect

Canopy lighting can be used to create a dramatic architectural effect as you would see in large colosseum, museum or even interior applications. Canopy lighting can be used to highlight artwork, architectural features or to create ambient illumination. The goal of canopy lighting is a smooth glow on the ceiling without being able to see the direct lighting source.

common distribution

Medium Flood Wide



INTENT - COLOR & WHITE
KFL - COLOR & WHITE



INTENT - WHITE
KFL - WHITE

CANOPY lighting

general guideline

In creating ambient lighting, the goal should be to achieve a uniform light level across the canopy so the light will reflect back to light the space (see page 38 for more information on reflection). In trying to achieve a dramatic affect, you can use other lighting effects such as grazing or highlighting to illuminate the architectural features of the canopy. Luminaires needs to be mounted high enough so occupants are unable to see the light source.



WHITE & COLOR

APPLICATIONS

GRAZING

WASHING

COLUMN LIGHTING

SIGN

CANOPY LIGHTING

SPOT LIGHTING

LANDSCAPE AND TREES

AREA LIGHTING

BRIDGES

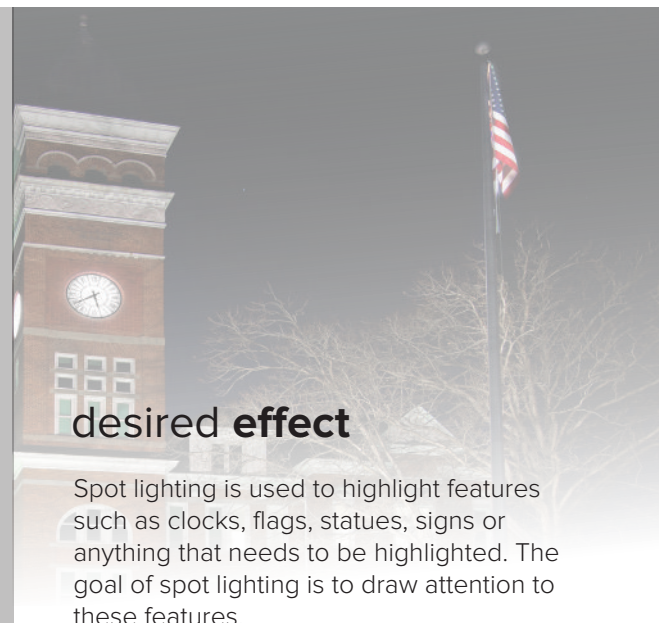

desired effect

Spot lighting is used to highlight features such as clocks, flags, statues, signs or anything that needs to be highlighted. The goal of spot lighting is to draw attention to these features.

common distribution

Spot



INTENT - COLOR
KFL - COLOR

Narrow



INTENT - COLOR & WHITE
KFL - COLOR & WHITE

SPOT lighting

general guideline

Spot lighting is best achieved with the fixtures setback away from the target to allow for uniform lighting. Typically spot lighting will use a narrow beam angle. However, wider beam angles can be used depending on the size of the target object. With larger setbacks, the distance between the illuminated surface and the luminaire need to be evaluated for objects that could obstruct the light, including occupants that may be walking through the space.



WHITE & COLOR

APPLICATIONS

GRAZING

WASHING

COLUMN LIGHTING

SIGN

CANOPY LIGHTING

SPOT LIGHTING

LANDSCAPE AND TREES

AREA LIGHTING

BRIDGES

desired effect

The goal of landscape lighting is to allow for the beauty of surrounding trees, shrubbery and flowers to extend into the night. Often, lighting can be used to add an additional dramatic effect to the landscape. High light levels are normally not needed unless it is also being used for ambient lighting in the space.

common distribution

Any

TREES

landscape

general guideline

Wide distributions are normally used for shrubbery and narrow for taller trees. Colored lighting is normally not used (see page 39 for more information on absorption).



WHITE & COLOR

APPLICATIONS

GRAZING

WASHING

COLUMN LIGHTING

SIGN

CANOPY LIGHTING

SPOT LIGHTING

LANDSCAPE AND TREES

AREA LIGHTING

BRIDGES

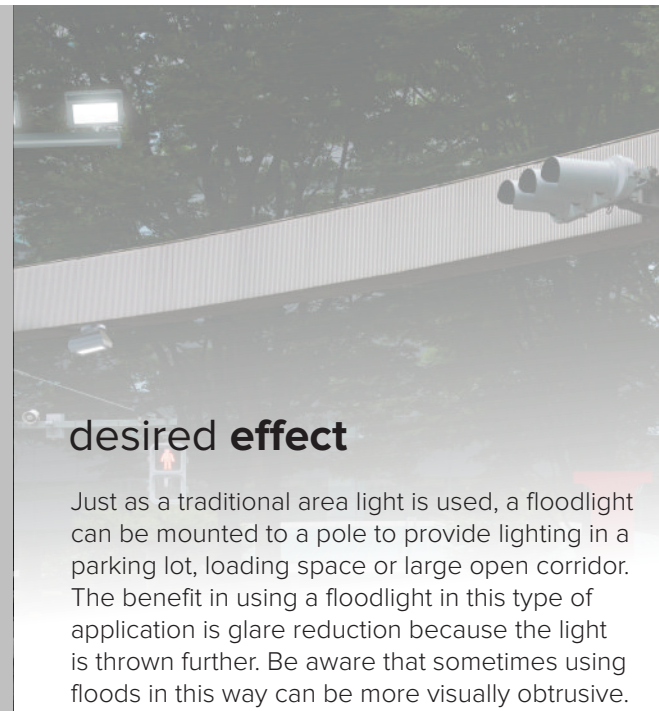

desired effect

Just as a traditional area light is used, a floodlight can be mounted to a pole to provide lighting in a parking lot, loading space or large open corridor. The benefit in using a floodlight in this type of application is glare reduction because the light is thrown further. Be aware that sometimes using floods in this way can be more visually obtrusive.

common distribution

Medium



INTENT - COLOR
KFL - COLOR & WHITE

Medium Flood



INTENT - COLOR & WHITE
KFL - COLOR & WHITE

Wide



INTENT - WHITE
KFL - WHITE

AREA lighting

general guideline

Area lighting is best achieved with higher mounting heights and wide beam angles. To reduce glare, it is best to keep the luminaires below a 65° tilt angle if possible. Floodlighting is also commonly mounted midway up the pole to supplement area lighting.



WHITE & COLOR

APPLICATIONS

GRAZING

WASHING

COLUMN LIGHTING

SIGN

CANOPY LIGHTING

SPOT LIGHTING

LANDSCAPE AND TREES

AREA LIGHTING

BRIDGES



desired effect

Floodlighting on bridges is used to highlight the vertical elements and architectural detail.

common distribution

Spot



INTENT - COLOR
KFL - COLOR

Narrow



KFL - COLOR & WHITE
KFL - COLOR & WHITE

BRIDGES

general guideline

Space restrictions normally limit the allowable setback on bridges, so more luminaires are required to achieve the desired effect. Shielding is also recommended as to not distract drivers or pedestrians when moving through the space.



DISTRIBUTIONS

APPLICATIONS

INTENT

STATIC WHITE

RGBW COLOR

KFL

STATIC WHITE

RGBW COLOR

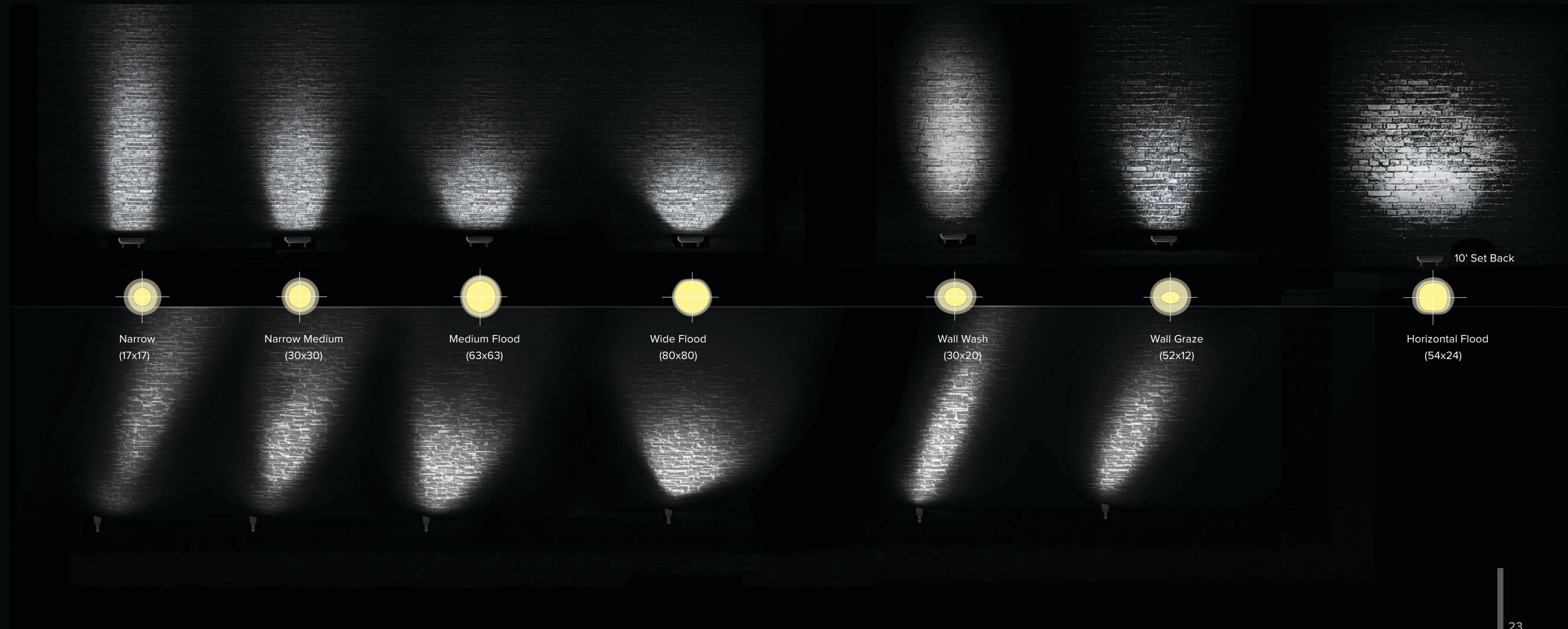

Narrow
(17x17)

Narrow Medium
(30x30)

Medium Flood
(63x63)

Wide Flood
(80x80)

Wall Wash
(30x20)

Wall Graze
(52x12)

Horizontal Flood
(54x24)

10' Set Back

DISTRIBUTIONS

APPLICATIONS

INTENT

STATIC WHITE

RGBW COLOR

KFL

STATIC WHITE

RGBW COLOR

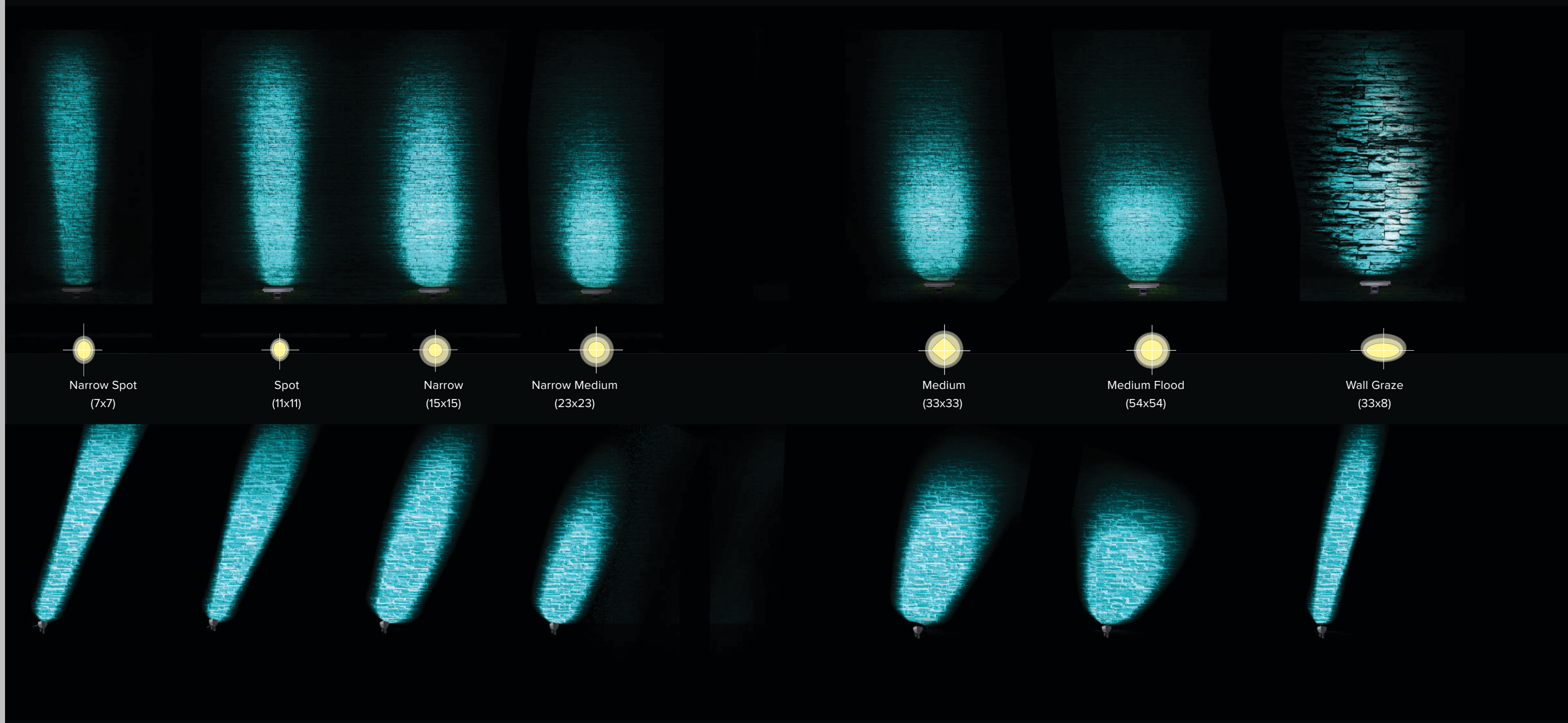

DISTRIBUTIONS

APPLICATIONS

INTENT

STATIC WHITE

RGBW COLOR

KFL

STATIC WHITE

RGBW COLOR

vertical distributions

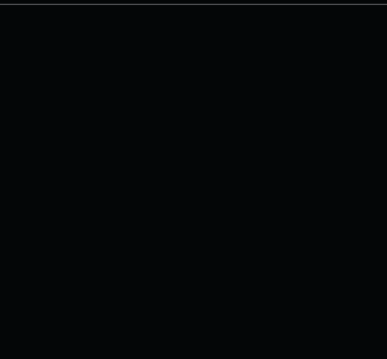
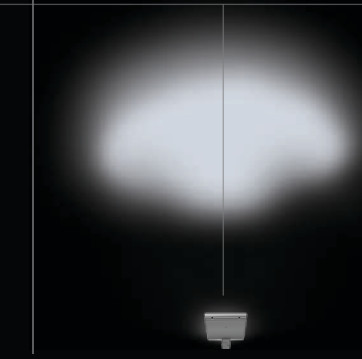
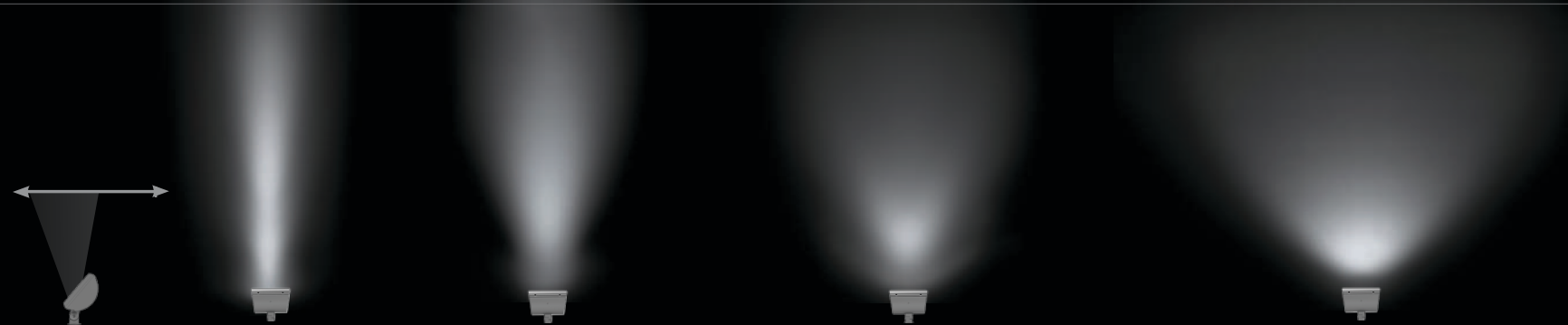
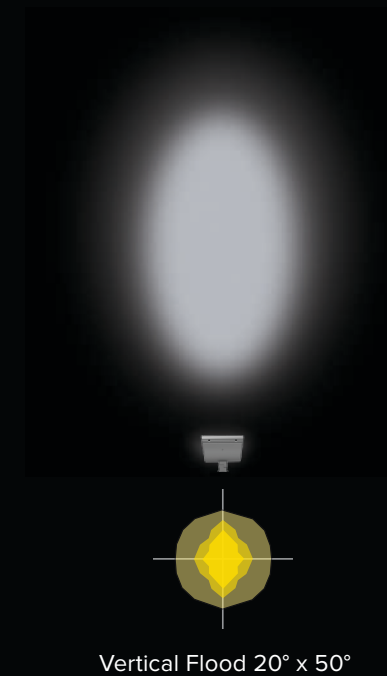
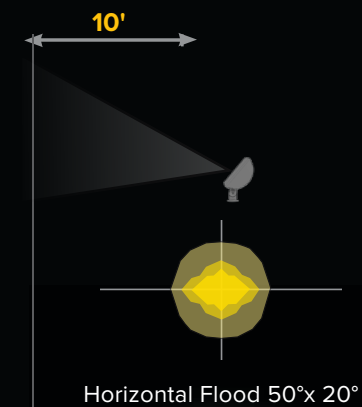
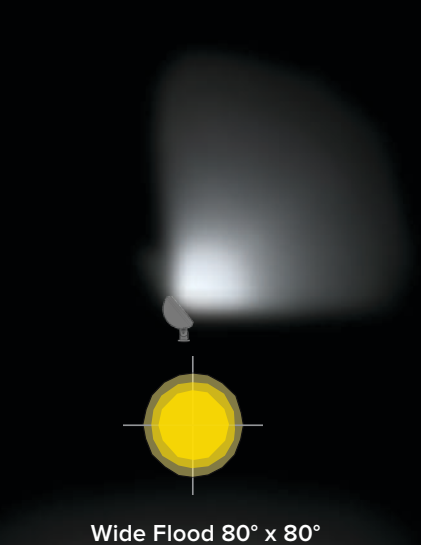
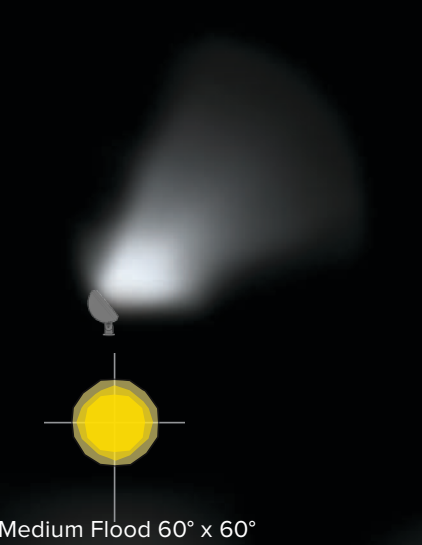
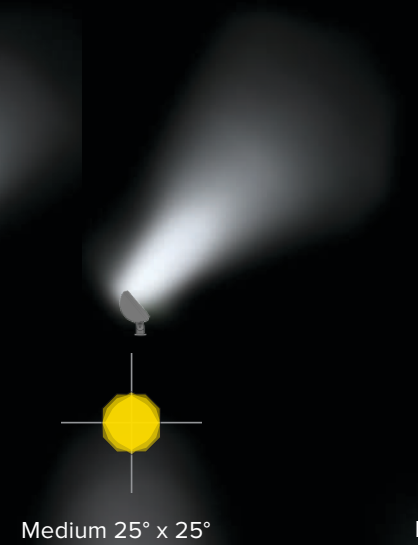
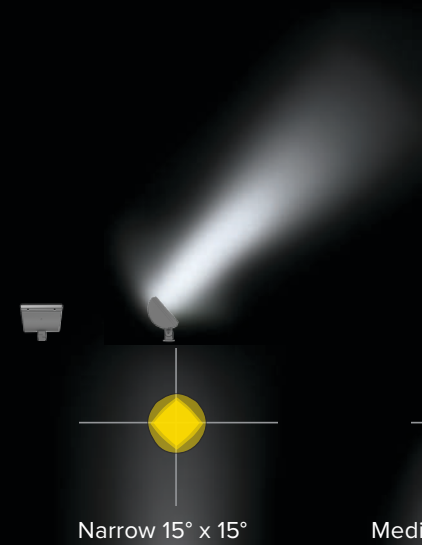

horizontal distributions

DISTRIBUTIONS

APPLICATIONS

INTENT

STATIC WHITE

RGBW COLOR

KFL

STATIC WHITE

RGBW COLOR

vertical distributions

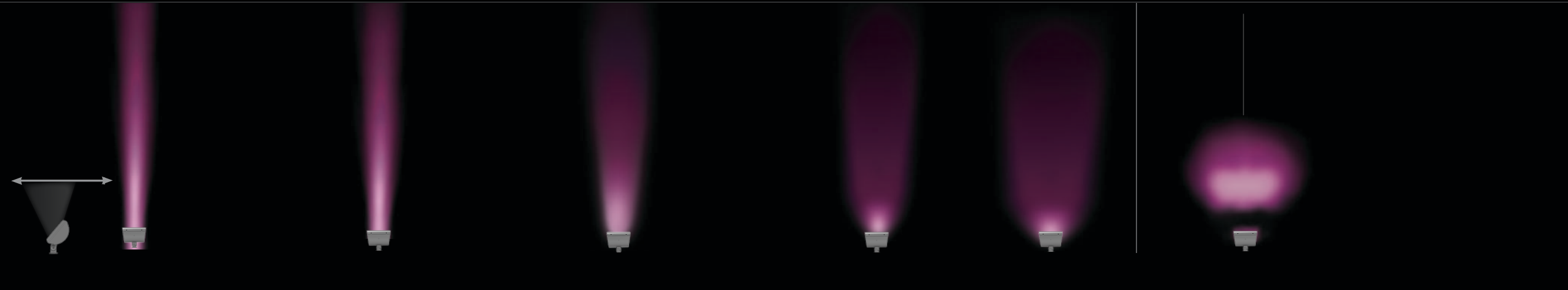
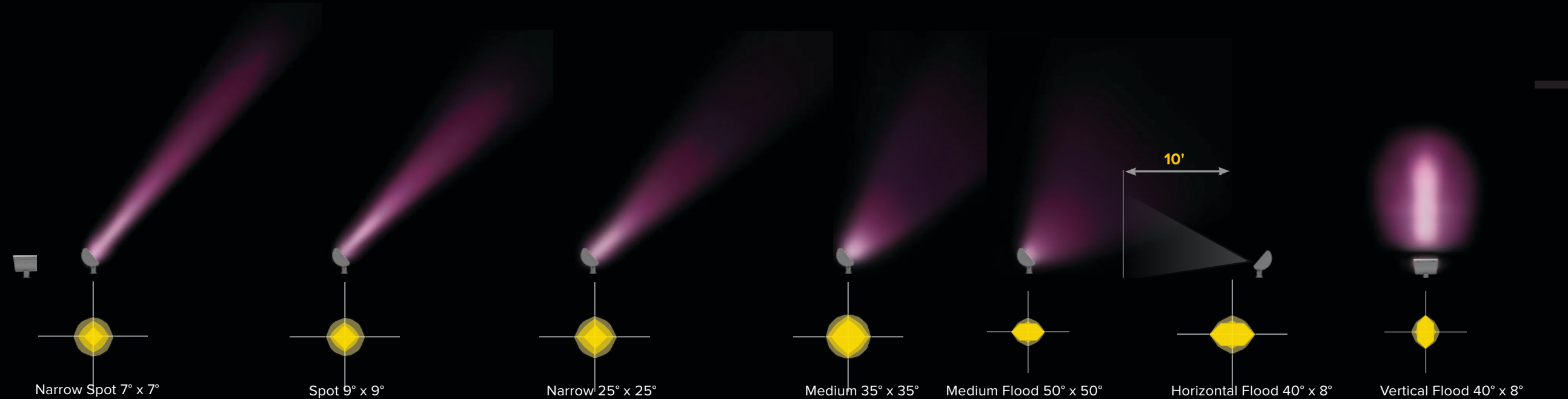

horizontal distributions

The KFL is available with six distinct distribution patterns to illuminate a variety of applications.

WHITE OPTICAL DESIGN

application considerations

All floodlighting applications have several considerations that must be measured before selecting the correct luminaire; **area being lit, illumination level, desired effect and mounting location.** Once these are determined, it becomes significantly easier to find the right **luminaire, output, distribution and mounting,** as long as you have the right tools.



VFL Vertical Flood

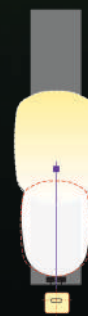

VFL Vertical Flood



NFL Narrow Flood

MULTIPLE BEAM COVERAGE

When a large area is to be illuminated, multiple fixtures are often required to produce satisfactory coverage of the target. By using complementary optical designs in combination, virtually any surface can be illuminated uniformly.

PATTERN OVERLAP

Increasing the overlap between adjacent beam patterns will reduce the contrast between illuminated areas and shadowing. However, shadow width will not be reduced, as this is a function of setback distance.

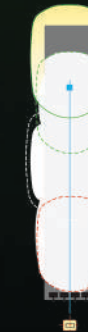

NFL Narrow Flood

COLOR

LIGHTING SURFACE

There are many ways that light can react when hitting a surface; reflection, refraction, transmittance, absorption, or a combination of any of those. Understanding these effects will help you understand how the light will appear in the application.

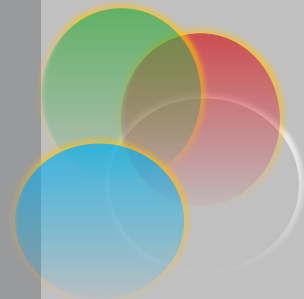

SET BACK 20'

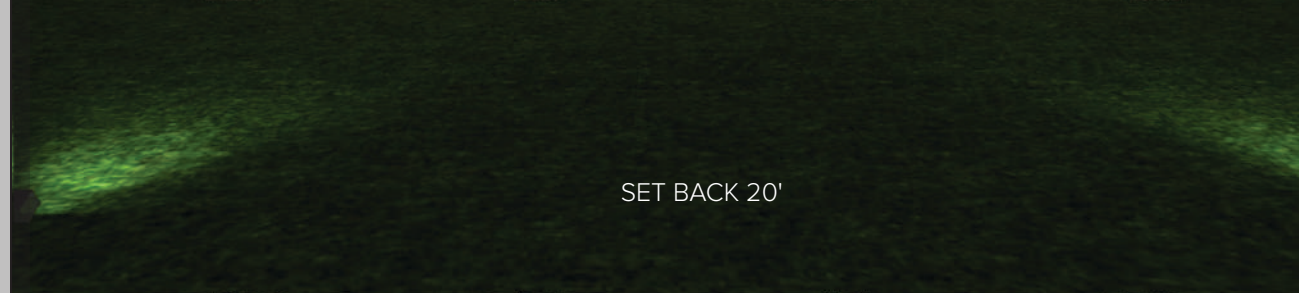

SET BACK 10'



SET BACK 5'



SETBACK EFFECTS

As the setback distance increases, the required beam pattern size decreases for the same target area. Although distribution plays into this as well. Narrowing the beam pattern as the setback increases retains the level of illumination and area of coverage.

SETBACK DISTANCE

One of the largest impacts on appearance of surface details is setback distance. The availability of a wide range of complementary optical distributions means that the appropriate setback distance can be used to achieve desired shadowing and surface appearance.

SHADOW WIDTH AND SETBACK DISTANCE

Shadowing from surface detail is inversely proportional to set back distance. Shallow set back distances render deep shadows. As setback distances increase, the depth of shadows decrease.

COLOR EFFECTS

blending RGB and White

Blending Red, Green, and Blue with a 6500K White LED produces opportunities to tune white light into any hue, with any degree of saturation desired. This allows lighting to be tuned to produce the desired surface appearance, enhanced or muted, that might be desired.

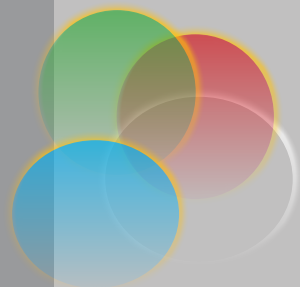

SpectraSync™ Color Tuning Technology
Dim-to-Warm

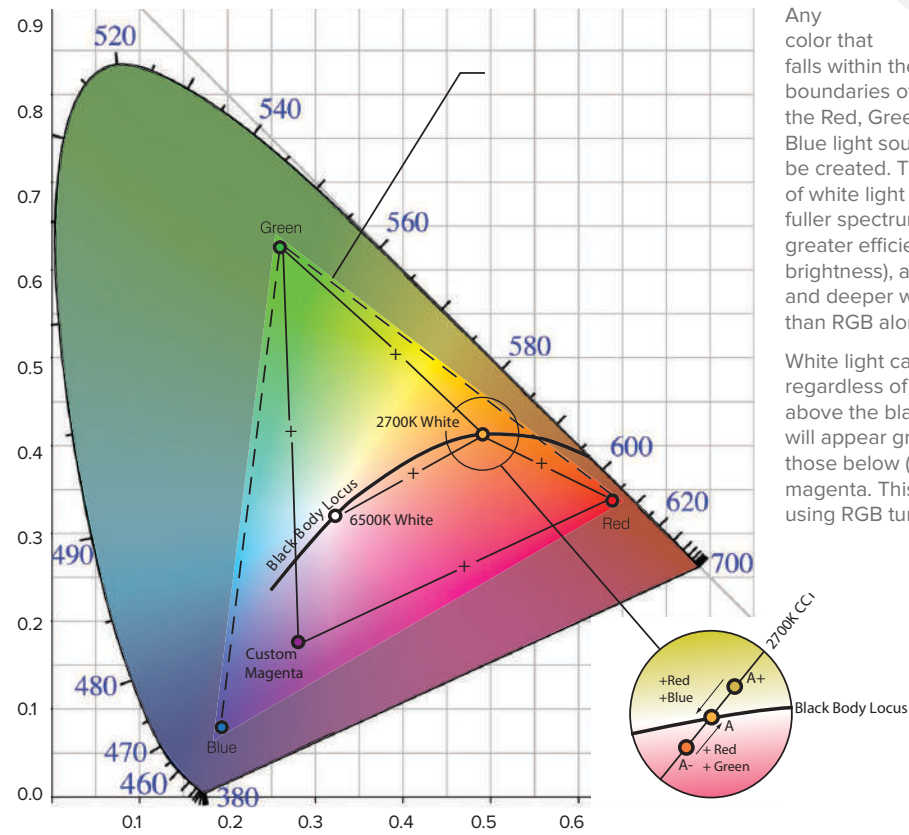

VISUAL RESPONSE TO SATURATED RGBW

Human visual response to color is not uniform. Red and Green produce a similar response, while blue does not. In color light application, when it is desirable to have saturated effects appear balanced in brightness, blue will require a significantly higher "dim" setting than either red or green.

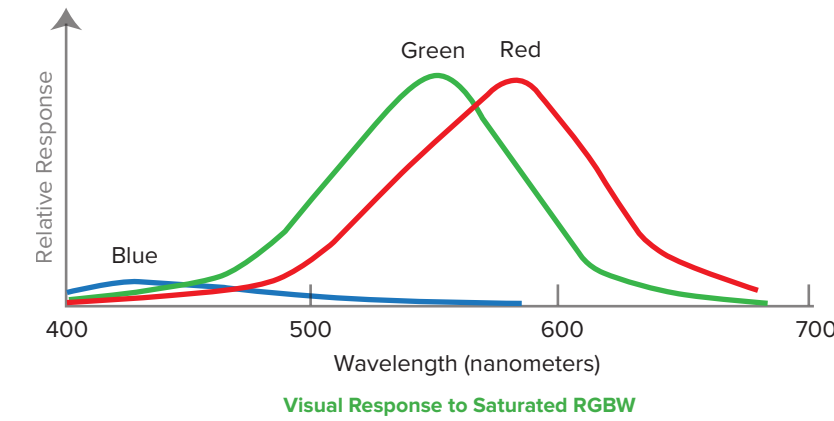

RGB+W CREATES WHITE LIGHT EFFECT

Blending white light with RGB color, produces a wide range of white light effects. Any hue can be created, from the warmth of candle light to cool blue moonlight, along with any pastel shade. This expands the range of a single white light source over the entire spectra, in addition to adding saturation and hue adjustment to suit a specific desired lighting effect to enhance or accent surfaces or landscape features.

RGB COMBINED TO MAKE WHITE

Mixing RGB colors will generate approximation of white light. The chart to the left shows the approximate values between Red, Green and Blue to create any shade of white light from warm dimmed incandescent to bright daylight.

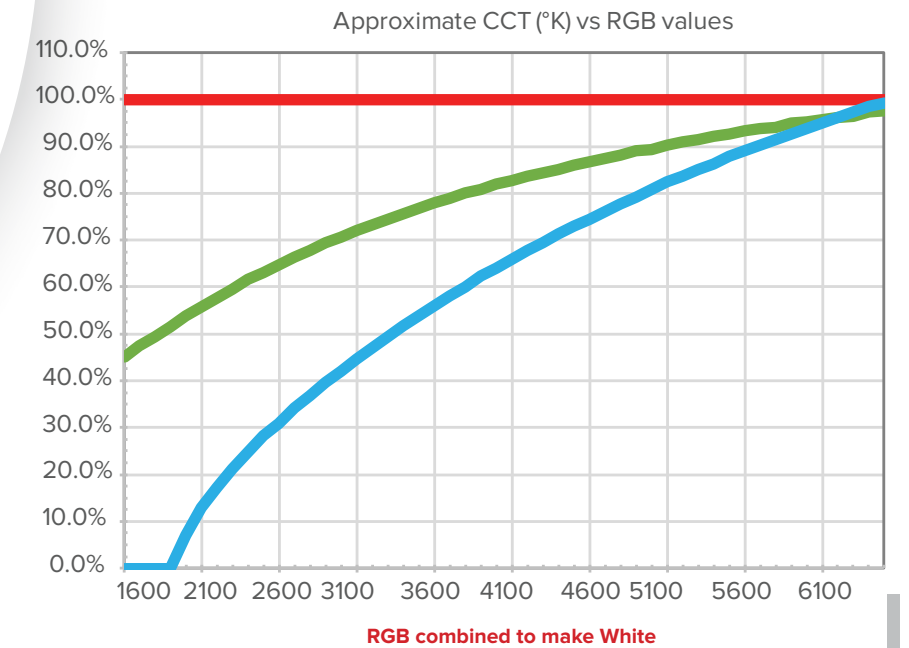
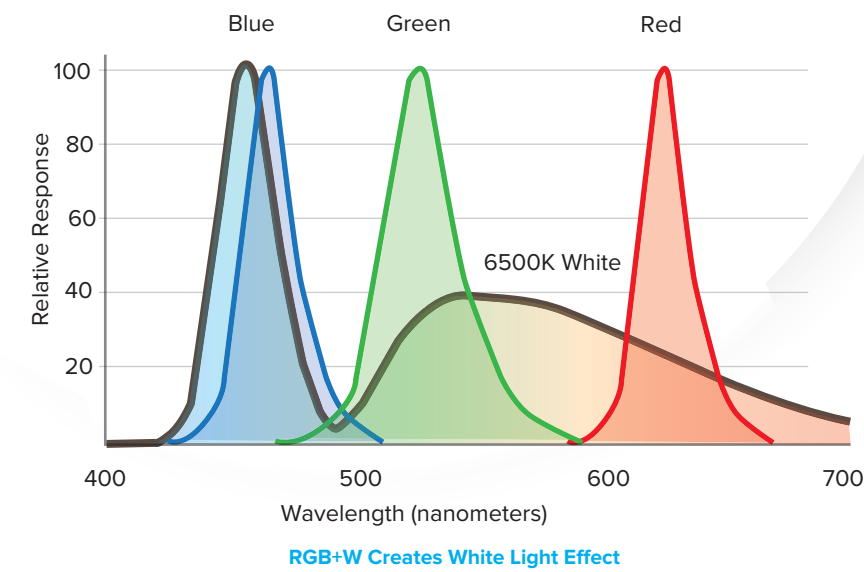

COLOR EFFECTS

mixing recipes

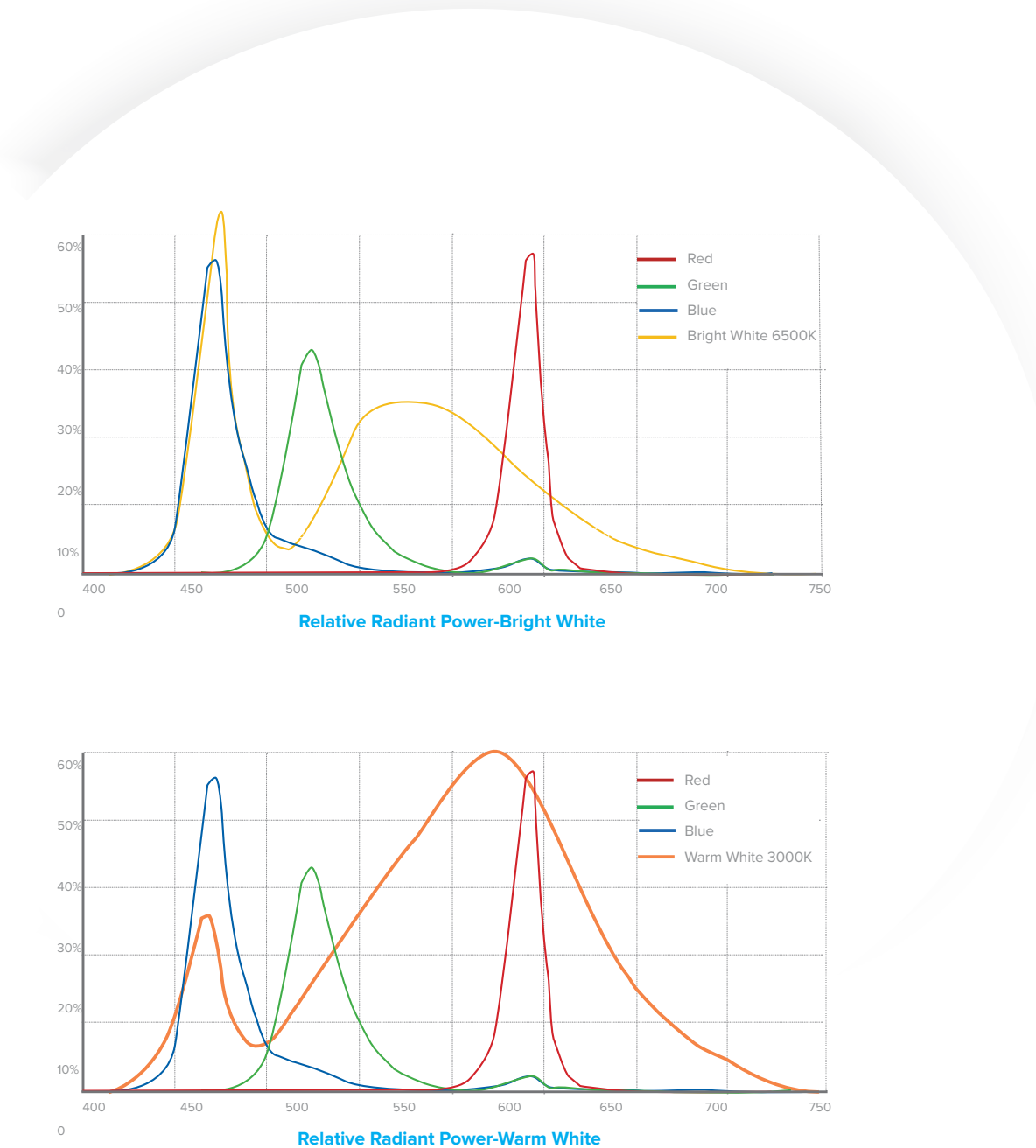
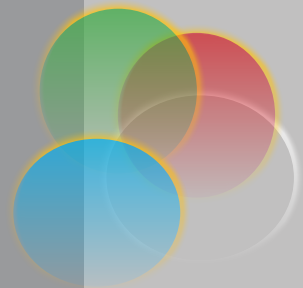

Blending Red, Green, and Blue with a 6500K White LED produces opportunities to tune White light into any hue, with any degree of saturation desired. This allows lighting to be tuned to produce the desired surface appearance, enhanced or muted, that might be desired.

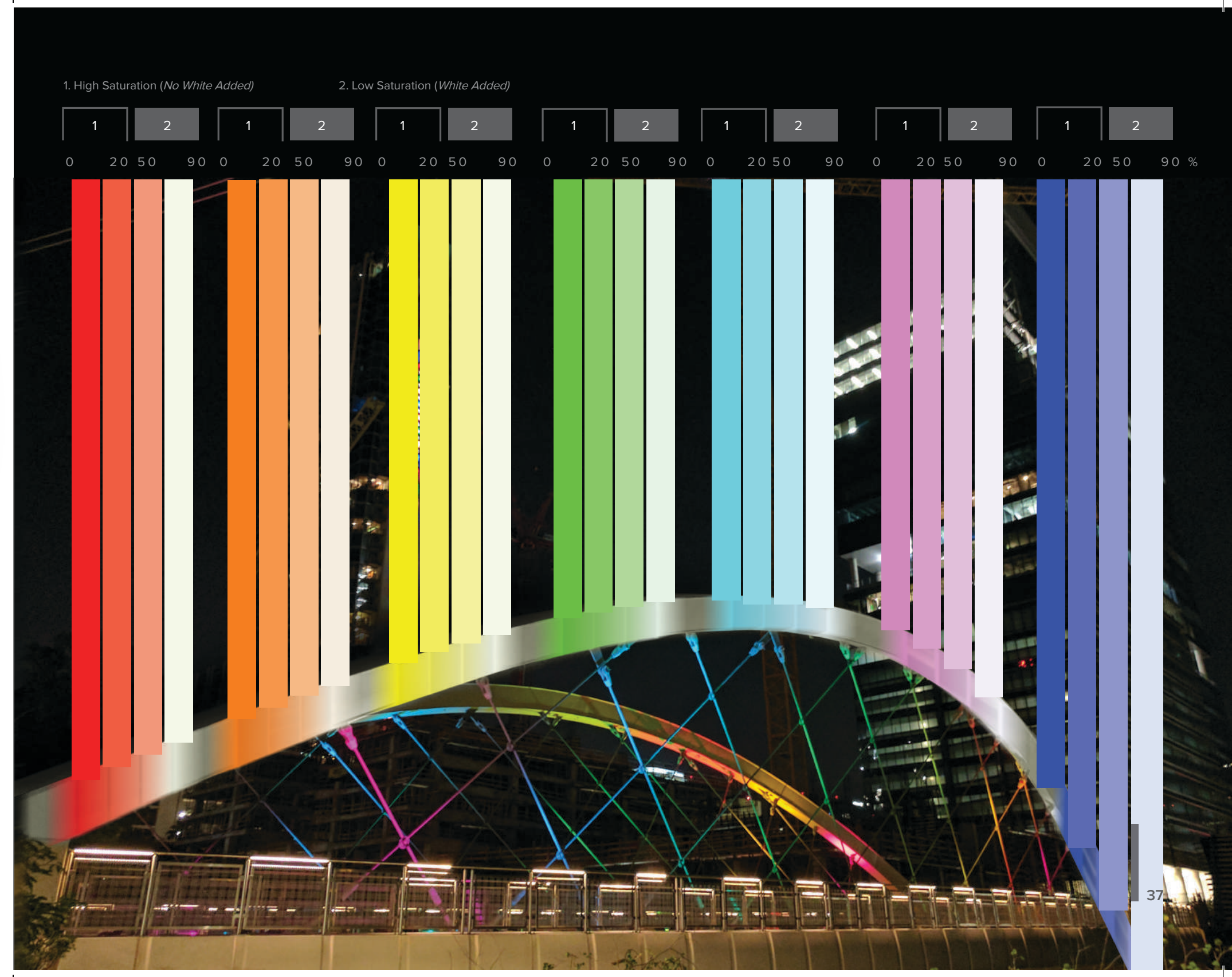

COLOR

LIGHTING SURFACE

There are four ways that light can react when hitting a surface; reflection, refraction, transmittance, absorption, or a combination of any of those. Understanding these effects will help you understand how the light will appear in the application.

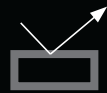
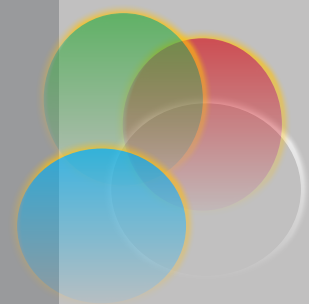

REFLECTION

A pure white surface reflects all colors meaning any and all colors from a light directed at a white surface will bounce off and fill back into the space. A white surface will appear the color of the light shining on it and will also reflect that color on other nearby objects. Reflectance is expressed as the percentage of light leaving the surface divided by the amount hitting the surface.

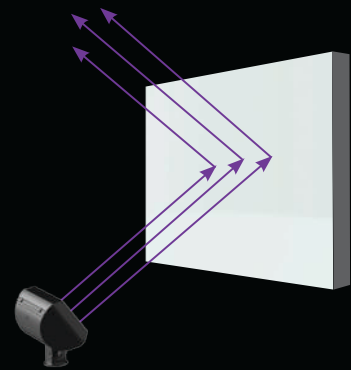

REFRACTION

As light enters and exits a transparent material, the beam angle will change direction. If the two surfaces are parallel the exit angle will equal the entry angle, for no net change in direction. An example of this is a window pane. If the two surfaces are not parallel, the light will bend. An example of this is a lens or a prism. In the case of the prism, white light can be separated into the colors that make up the white light. Water droplets can also act like a lens and separate colors into a rainbow.

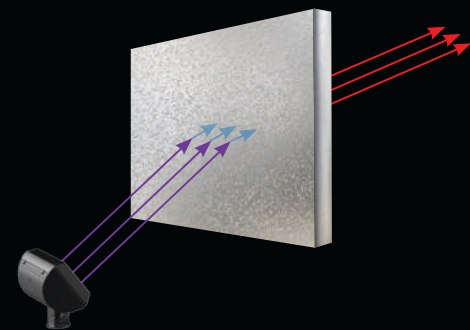

ABSORPTION

As referenced above, pure white surfaces will reflect all colors, but colored surfaces will absorb some light. This means that when working with colored light it can get tricky to predict the appearance it will have on a colored surface. If the surface color does not contain the color of the light, all light will be absorbed, resulting in a false black appearance.

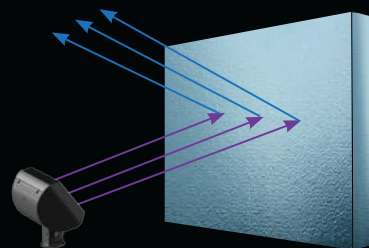

Colored surfaces, on the other hand, appear their respective color because they absorb the light that does not match their color. For example if white light is shining on a red surface, the surface is reflecting back only the red component of the white light, absorbing the rest and appearing red. This means that when working with colored light it can get tricky to predict the appearance it will have on a colored surface. If a light source does not contain the color of the object, then there is none of that color to be reflected back, and the object will appear black. An example of this would be if you shine purple light on a green object. With no green in the light source, the object simply appears black.



TRANSMITTANCE

Transmittance occurs when light travels through a transparent media. The media can be gas, solid or liquid. The best examples of this are air (gas), glass (solid) or water (liquid). As light travels through the media some light will be absorbed. Because light either travels through the material or is absorbed, no light is reflected off of the surface and cannot be perceived on the surface.



CONSTRUCTION

MOUNTING OPTIONS

KFL

KFL1

KFL2

KFL3

INTENT

INT



Knuckle (K)



Junction Box (JBR)

Architectural Junction Box (JB1)

In-Grade Staked Box (JBR30/32)

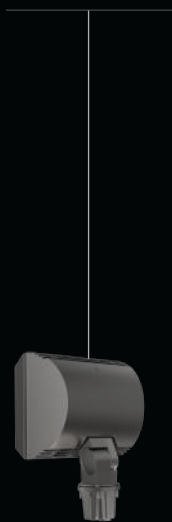

KFL1-K-JBR



KFL1-K-JB1



KFL1-K-JBR30



Yoke (Y)



Knuckle (K)



Wall Mount (WM1)

Side Pole (SPM)

Twin Mount (PT2)

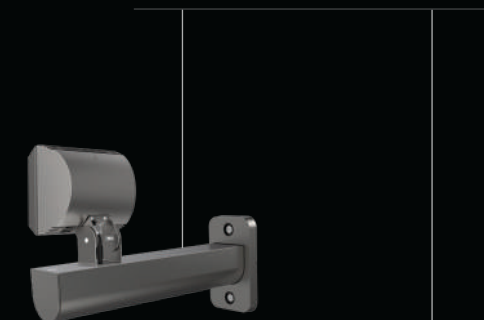

KFL1-Y-WM

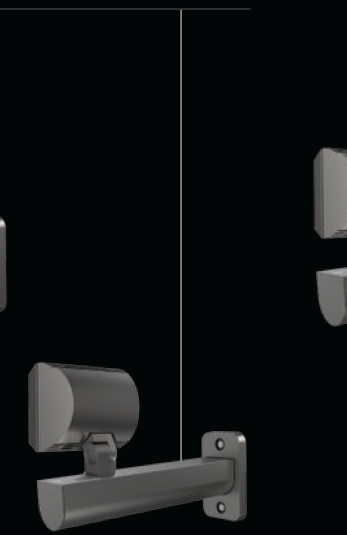

KFL1-K-WM



KFL1-Y-SMP

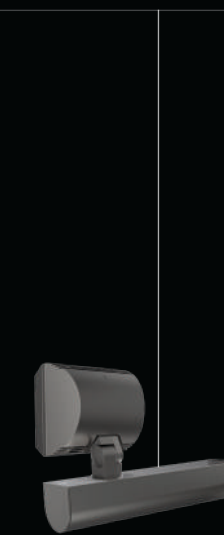

KFL1-K-SMP



KFL1-Y-TM2



KFL1-K-TM2

Dimensions are for illustration purposes only.

CONSTRUCTION

MOUNTING OPTIONS

KFL

KFL1

KFL2

KFL3

INTENT

INT



Knuckle (K)

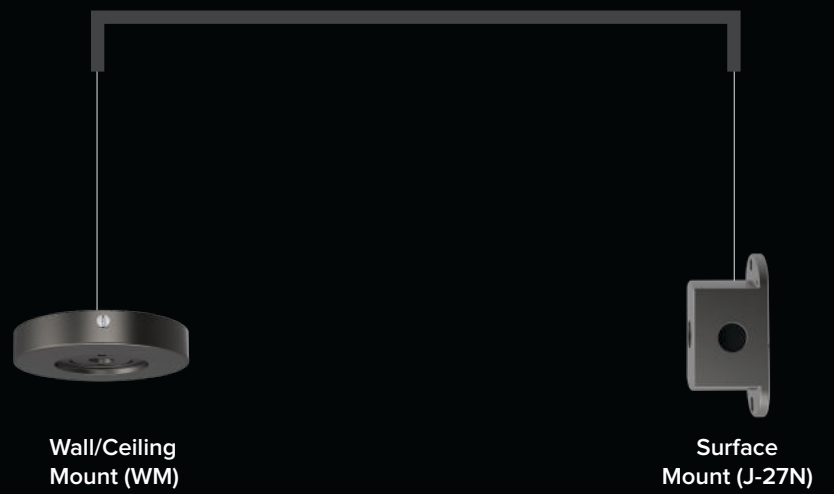

Wall/Ceiling Mount (WM)

Surface Mount (J-27N)



KFL1-K-WM



KFL1-K-J-27N

Dimensions are for illustration purposes only.



Yoke (Y)

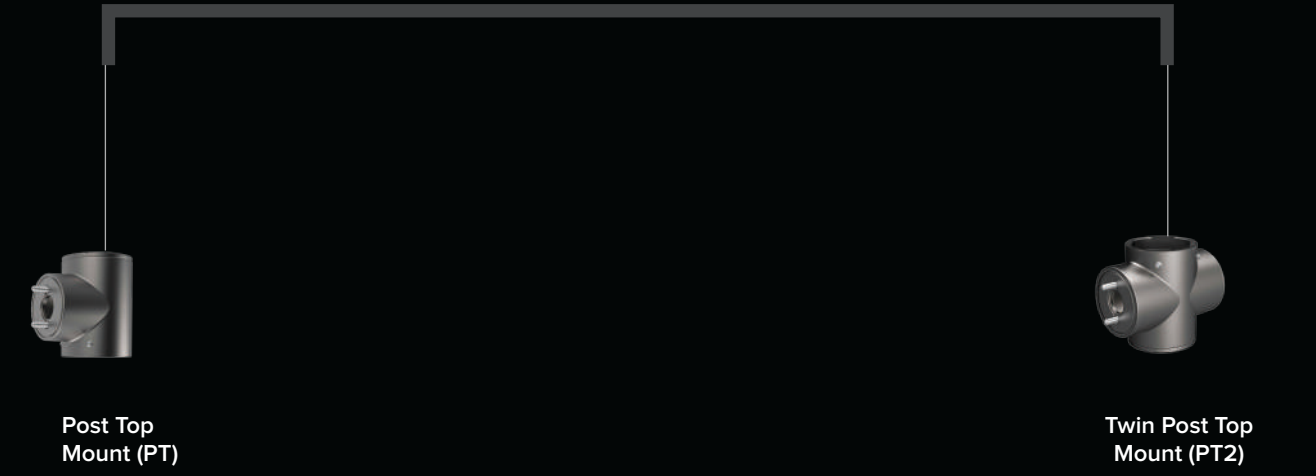

Post Top Mount (PT)

Twin Post Top Mount (PT2)



KFL1-Y-PT



KFL1-Y-PT2



KFL1-K-PT



KFL1-K-PT2

CONSTRUCTION

MOUNTING OPTIONS

KFL

KFL1

KFL2

KFL3

INTENT

INT



Knuckle (K)

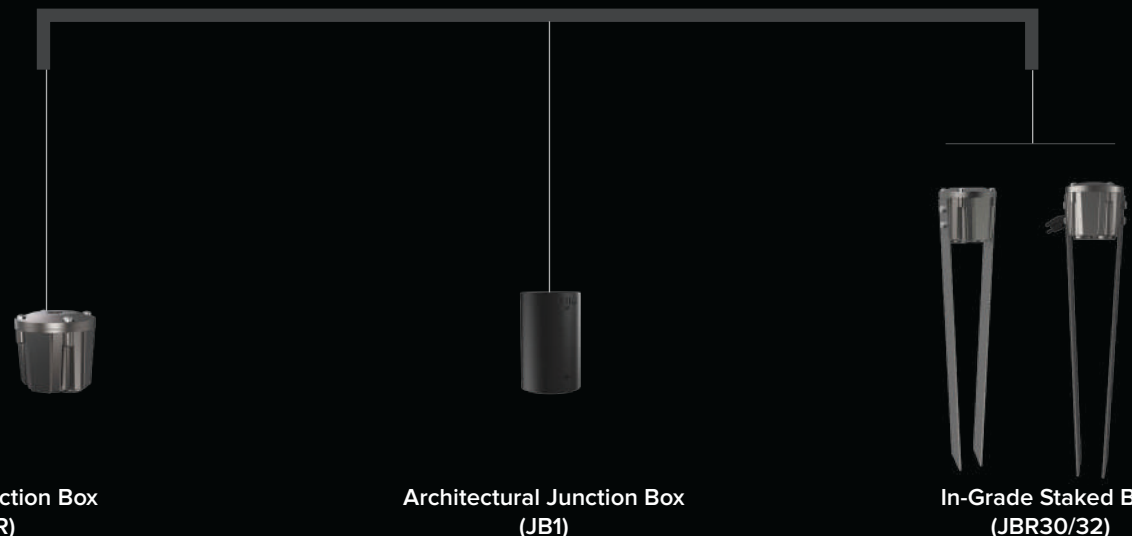

Junction Box (JBR)

Architectural Junction Box (JB1)

In-Grade Staked Box (JBR30/32)



KFL2-K-JBR



KFL2-K-JB1



KFL2-K-JBR30



Yoke (Y) Knuckle (K)

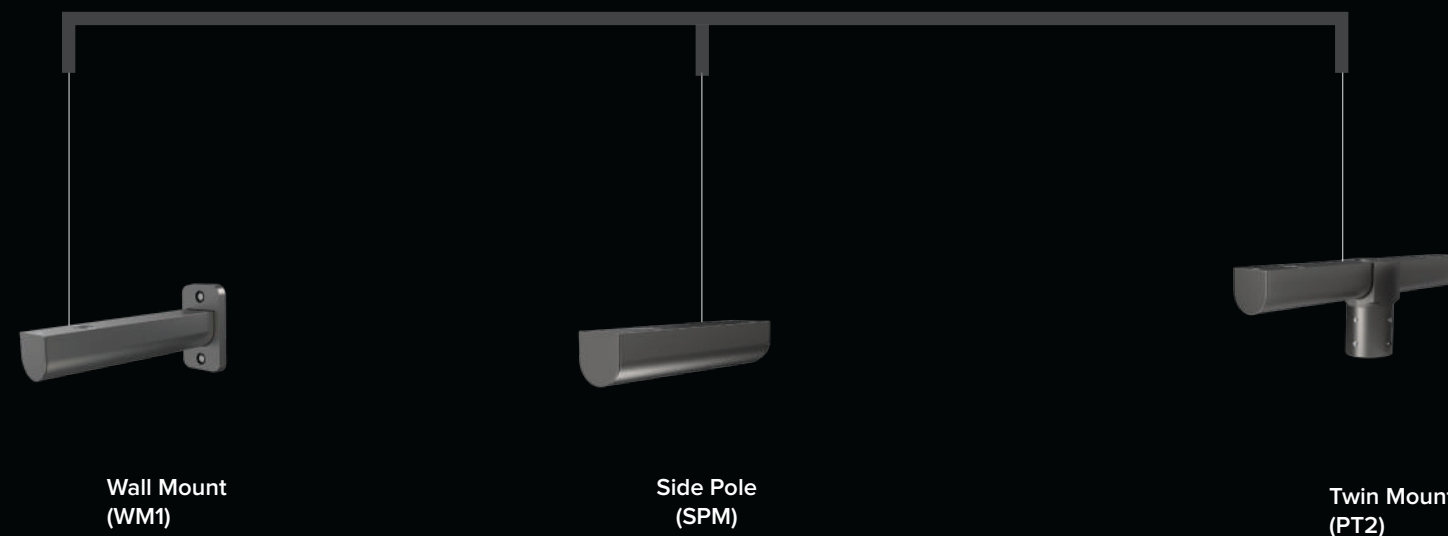

Wall Mount (WM1)

Side Pole (SPM)

Twin Mount (PT2)



KFL2-Y-WM

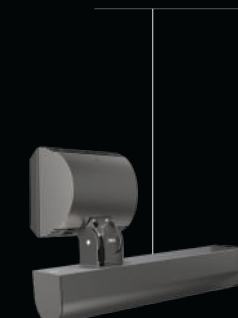

KFL2-Y-SMP



KFL2-Y-TM2



KFL2-K-WM



KFL2-K-SMP



KFL2-K-TM2

Dimensions are for illustration purposes only.

CONSTRUCTION

MOUNTING OPTIONS

KFL

KFL1

KFL2

KFL3

INTENT

INT



Knuckle (K)

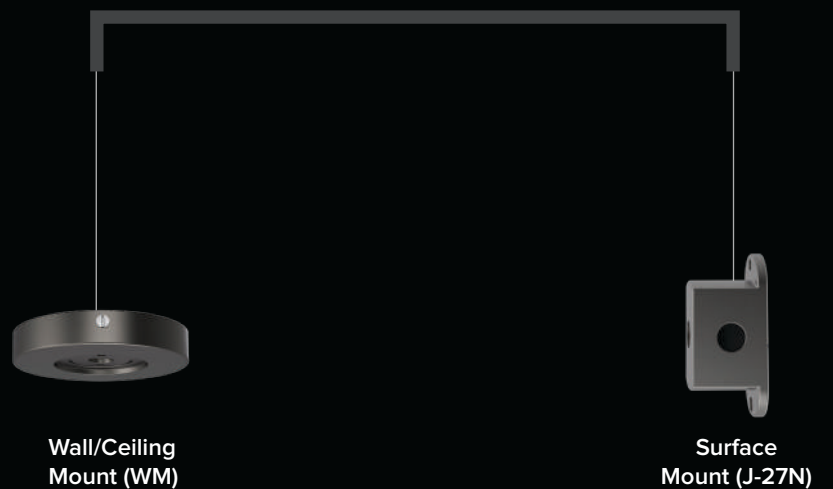

Wall/Ceiling Mount (WM)

Surface Mount (J-27N)

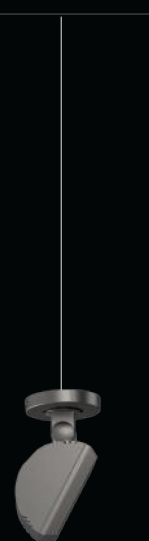

KFL2-K-WM

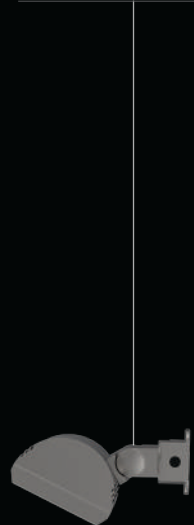

KFL2-K-J-27N

Dimensions are for illustration purposes only.



Yoke (Y)

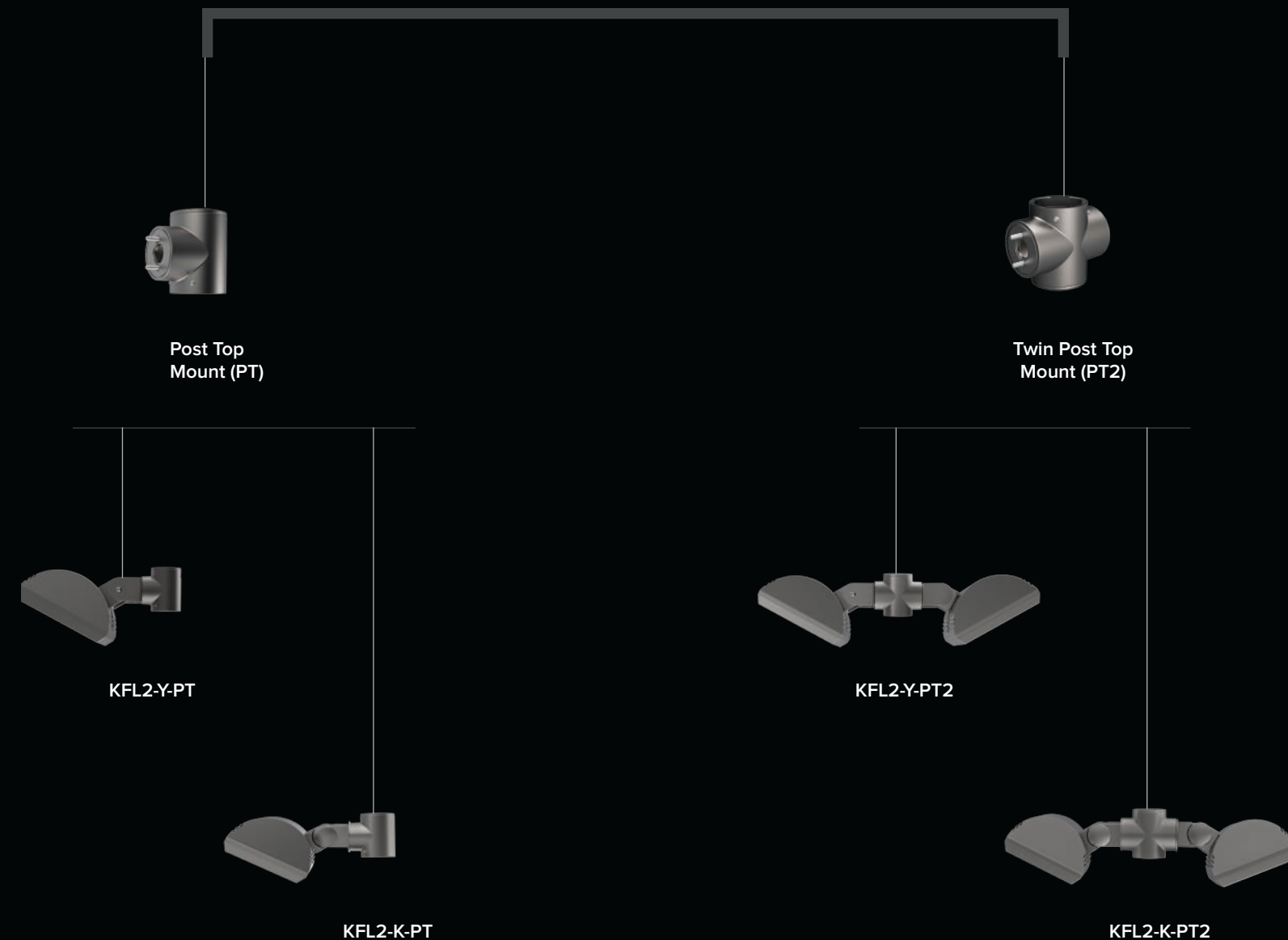

KFL2-Y-PT

KFL2-Y-PT2

KFL2-K-PT

KFL2-K-PT2

CONSTRUCTION

MOUNTING OPTIONS

KFL

KFL1

KFL2

KF3

INTENT

INT



Knuckle (K)

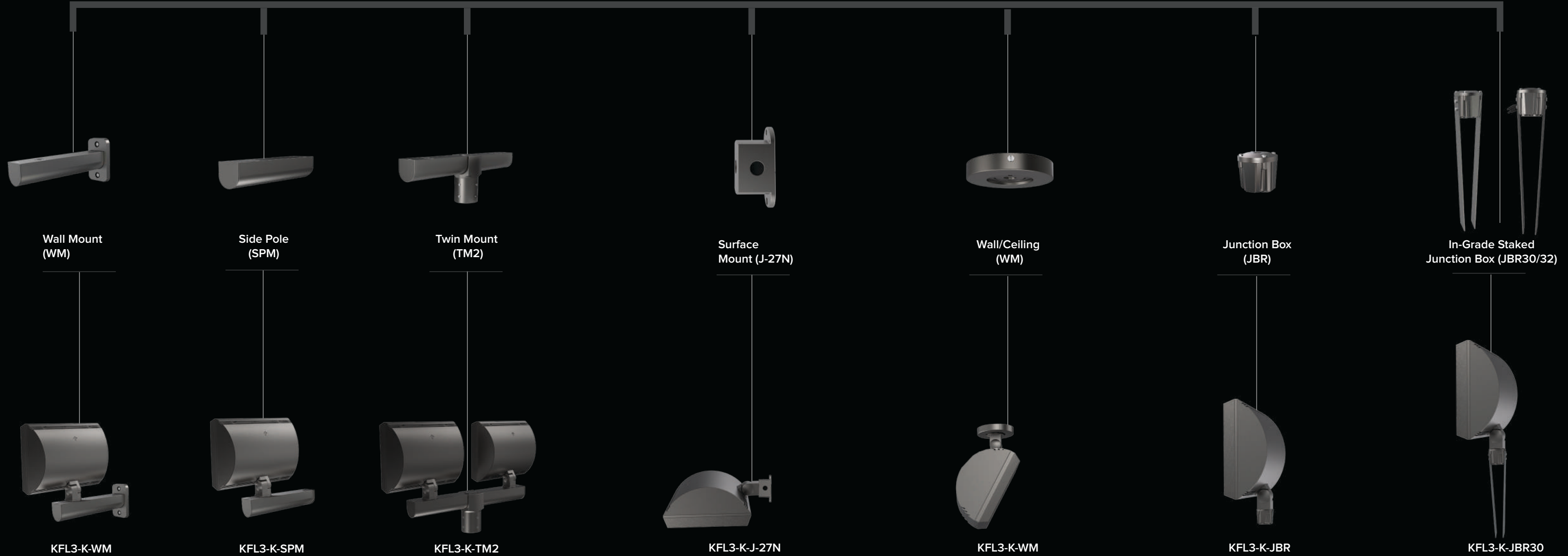

Wall Mount (WM)

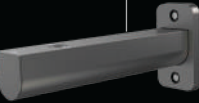

KFL3-K-WM

Side Pole (SPM)

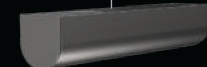

KFL3-K-SPM

Twin Mount (TM2)



KFL3-K-TM2

Surface Mount (J-27N)

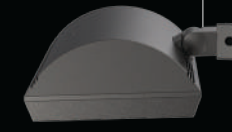

KFL3-K-J-27N

Wall/Ceiling (WM)



KFL3-K-WM

Junction Box (JBR)



KFL3-K-JBR

In-Grade Staked Junction Box (JBR30/32)



KFL3-K-JBR30

Dimensions are for illustration purposes only.

CONSTRUCTION

MOUNTING OPTIONS

KFL

KFL1

KFL2

KF3

INTENT

INT



Slipfitter (S)



Side Pole Tenon (SPT)



KFL3-S-SPT



Surface Mount Tenon (SMT)



KFL3-S-SMT



Twin Mount Tenon (M2B)



KFL3-S-M2B



Triple Mount Tenon (M3E)



KFL3-S-M3E

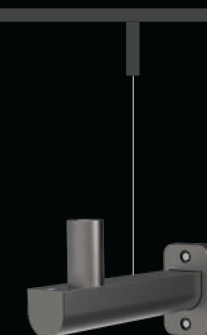

Wall Mount Tenon (WM2)



KFL3-S-M2B



Stanchion Tenon (SM2)



KFL3-S-SM2

Dimensions are for illustration purposes only.

CONSTRUCTION

MOUNTING OPTIONS

KFL

- KFL1
- KFL2
- KFL3

INTENT

INT

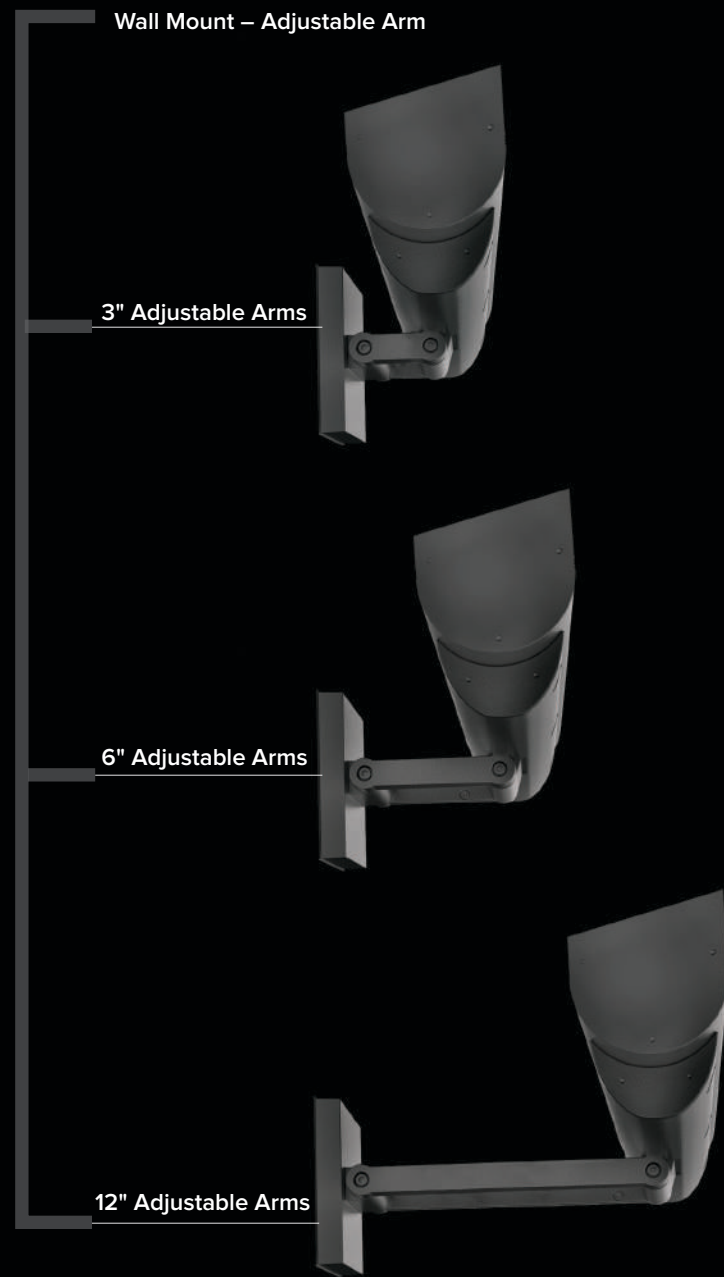

Dimensions are for illustration purposes only.

AIMING

KFL

INT

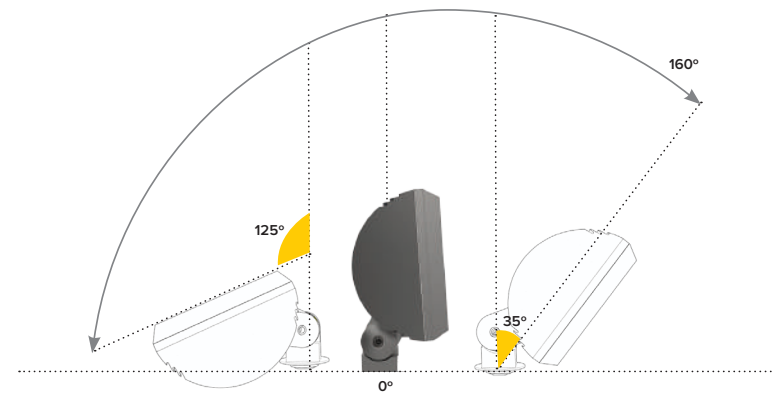

Standard Swivel
(Total 160°)

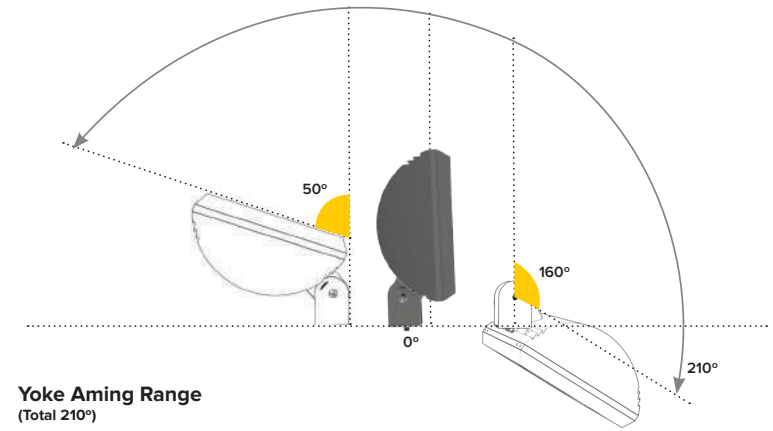

Yoke Aiming Range
(Total 210°)

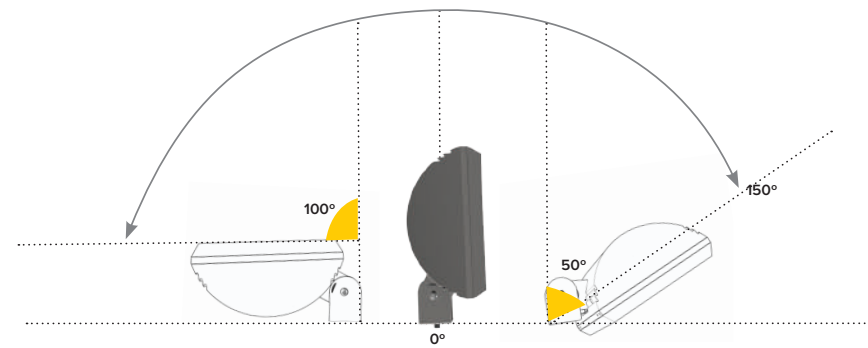

Yoke Aiming Range with Ground Restriction (Total 150°)

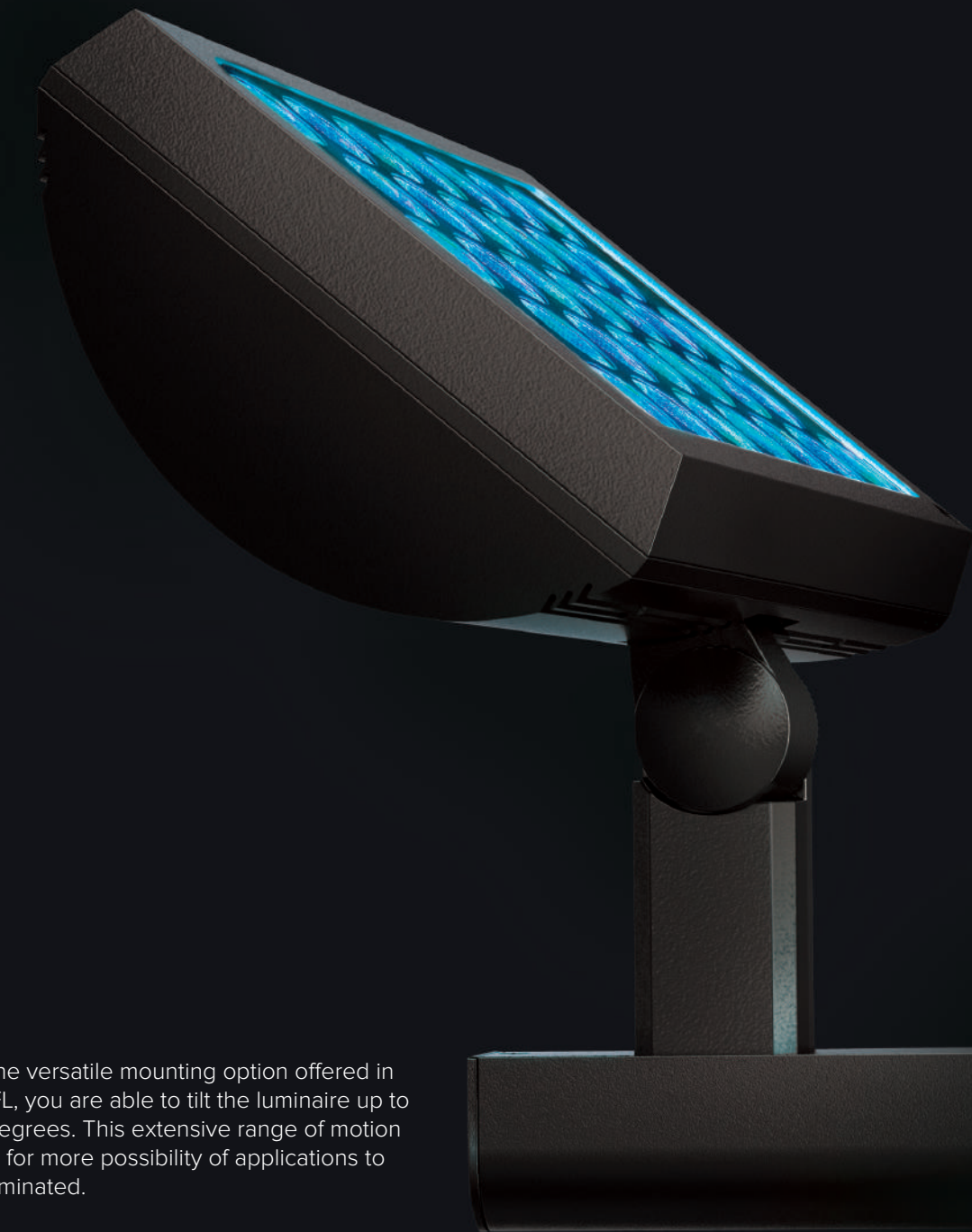

With the versatile mounting option offered in the KFL, you are able to tilt the luminaire up to 290 degrees. This extensive range of motion allows for more possibility of applications to be illuminated.

AIMING

KFL
INT

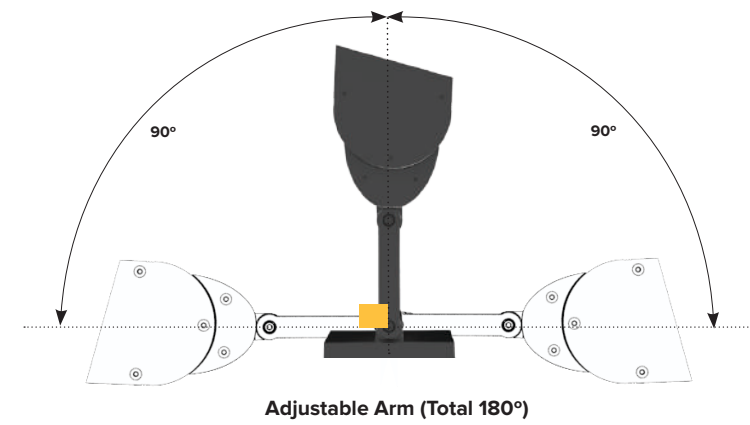
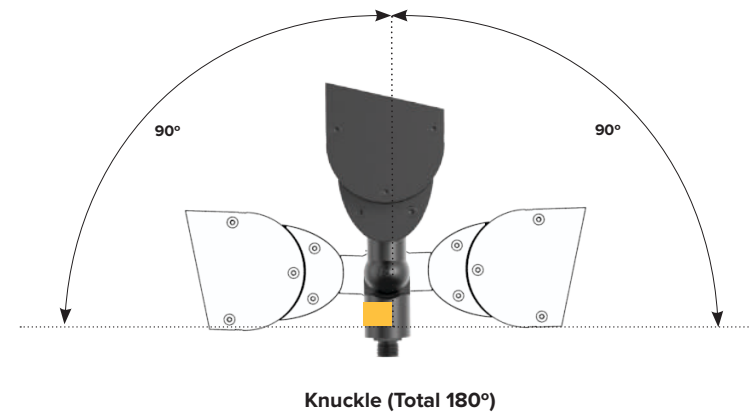

The Intent features a Knuckle and Adjustable Arm Mount which is able to pivot 180 degrees allowing for tailored made aiming.

OPTICAL
ACCESSORIES

KFL

INT

KFL

Barn Door and Half Glare Shield optical options allows for more customization and reduction of unnecessary glare.

INTENT

For additional glare control, the Intent offers louvers that are both functional and architectural in look and function.

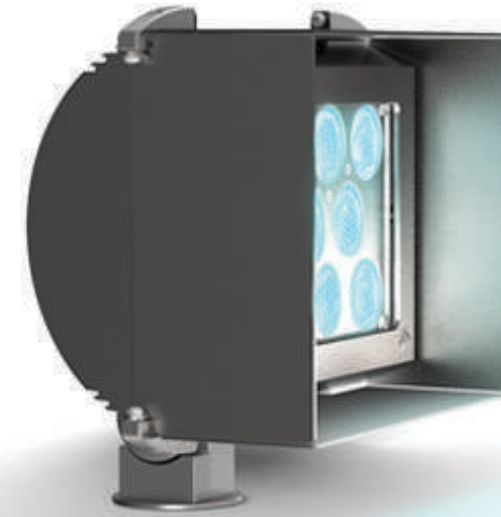

barn door (BD)

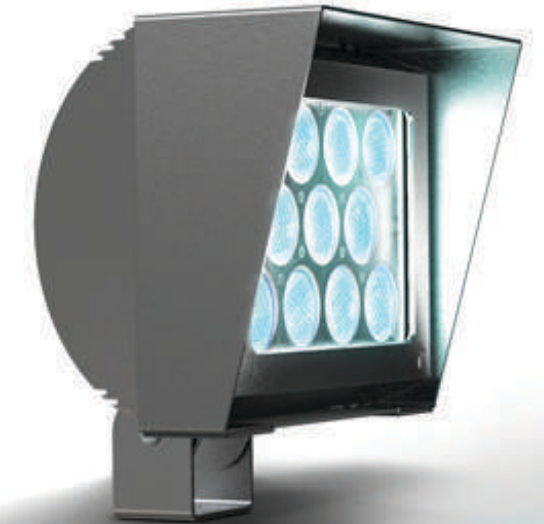

half glare shield (HS)

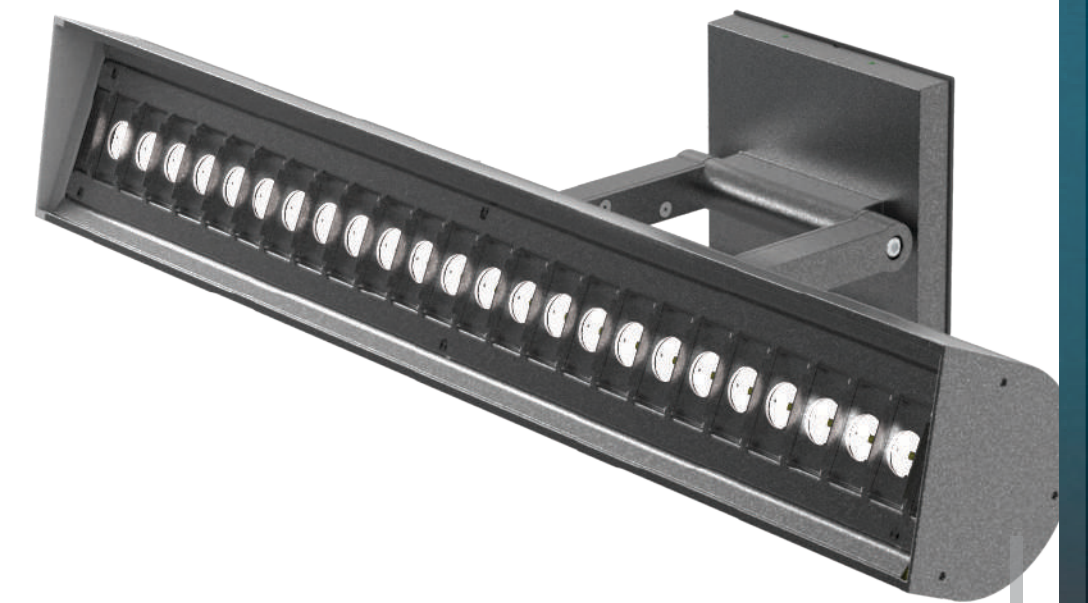

louver (LVR)



ARCHITECTURAL AREA LIGHTING

BEACON PRODUCTS

COLUMBIA LIGHTING

COMPASS

DUAL-LITE

HUBBELL CONTROL SOLUTIONS

HUBBELL OUTDOOR LIGHTING

KIM LIGHTING

KURT VERSEN

LITECONTROL

PRESCOLITE

KIMLIGHTING

701 Millennium Blvd. Greenville, SC 29607

Tel 864.678.1000

Kim-007 10/01/2020 Edition 1

Copyright © 2020 Kim Lighting, a division of Hubbell Lighting, Inc. All rights reserved. Please refer to online specifications for most up-to-date content as specifications are subject to change without notice.